

# High Output Current External Voltage Regulator

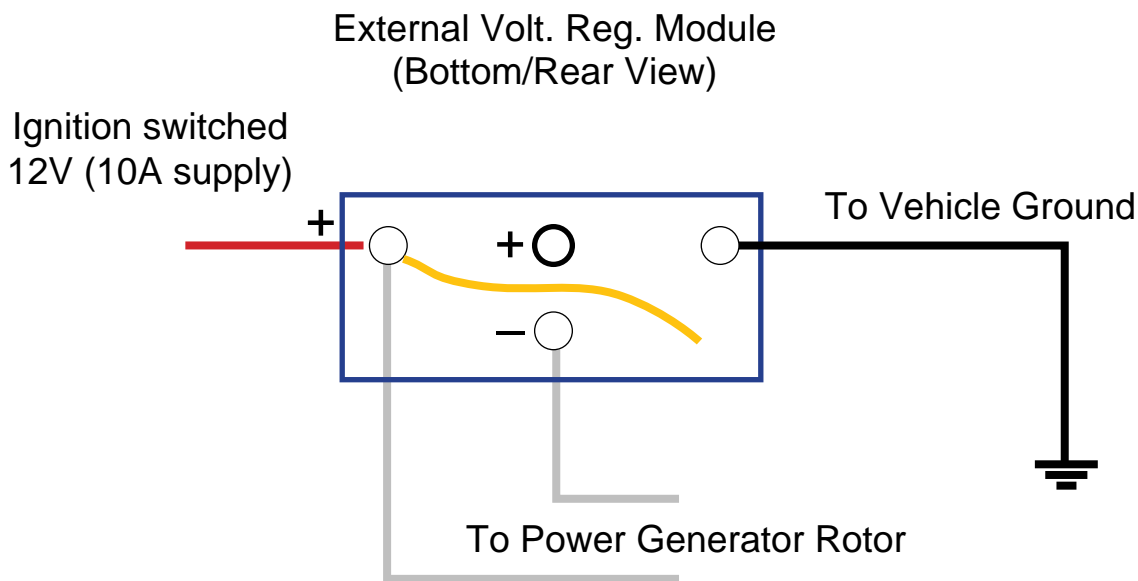

## NOTES / INSTRUCTIONS:

- 1) This external voltage regulator is an A-Circuit type regulator (continuous 12V to one leg of rotor, active ground to other leg). As wired this regulator is ignition excited/triggered. It can also be excited by either stator or diode trio. The Yellow wire is the input to the trigger circuit. If the regulator is to be excited by stator or diode trio, the yellow wire is removed from the positive terminal and attached to the appropriate trigger point.
- 2) The schematic above shows how the regulator is attached to the ZENA power generator.
- 3) The Power Generator Rotor can draw as much as 8 amps. Make sure that supply current is sufficient. Proper voltage regulation requires a good current source.  
**IF YOU DO NOT HAVE A SWITCHED IGNITION SOURCE THAT CAN SUPPLY SUFFICIENT CURRENT USE A HIGH CURRENT RELAY TO SUPPLY CURRENT FROM BATTERY -- WITH RELAY SWITCHED BY IGNITION.**
- 4) The voltage regulator's heat sink/case is not grounded. Grounding the heat sink/case will not affect operation of regulator.
- 5) This is a 14V regulator with adjustable output voltage. It should be set to the system charging voltage recommended by the vehicle manufacturer. For aggressive charging, set voltage slightly higher than 14V (but no greater than 14.4V, for less aggressive charging set voltage to slightly LESS than 14V (13.8V is a common set point). To reach the adjustor, temporarily remove plastic cap covering the screwdriver adjustment point on heat sink/case.  
**MEASURE VOLTAGE AT THE BATTERY AND USE A PRECISION VOLTMETER WHICH HAS BEEN PROPERLY CALIBRATED.**
- 6) Maximum output from the Power Generator is produced at higher engine speeds. Using an automatic engine speed control or some other means to increase engine speed will insure fastest possible battery charging or maximum extra power for accessories.